

SN5446A, '47A, '48, SN54LS47, 'LS48, 'LS49 SN7446A, '47A, '48, SN74LS47, 'LS48, 'LS49 BCD-TO-SEVEN-SEGMENT DECODERS/DRIVERS

SDLS111 – MARCH 1974 – REVISED MARCH 1988

'46A, '47A, 'LS47 feature

- Open-Collector Outputs Drive Indicators Directly
- Lamp-Test Provision
- Leading/Trailing Zero Suppression

'48, 'LS48 feature

- Internal Pull-Ups Eliminate Need for External Resistors
- Lamp-Test Provision
- Leading/Trailing Zero Suppression

'LS49 feature

- Open-Collector Outputs
- Blanking Input

SN5446A, SN5447A, SN54LS47, SN5448,
SN54LS48 . . . J PACKAGE
SN7446A, SN7447A,
SN7448 . . . N PACKAGE
SN74LS47, SN74LS48 . . . D OR N PACKAGE

(TOP VIEW)

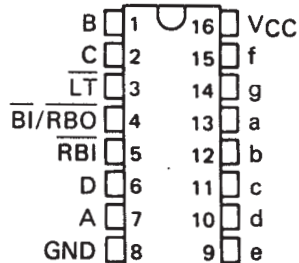

SN54LS47, SN54LS48 . . . FK PACKAGE
(TOP VIEW)

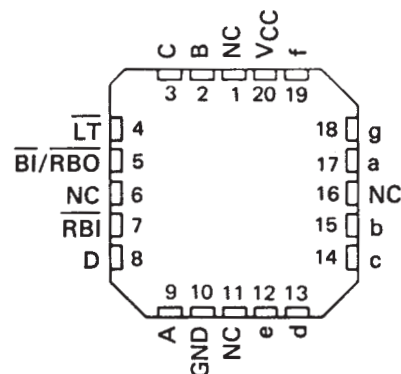

SN54LS49 . . . J OR W PACKAGE
SN74LS49 . . . D OR N PACKAGE

(TOP VIEW)

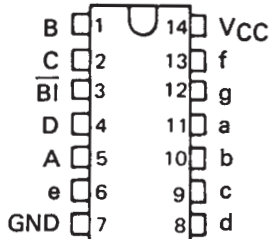

SN54LS49 . . . FK PACKAGE
(TOP VIEW)

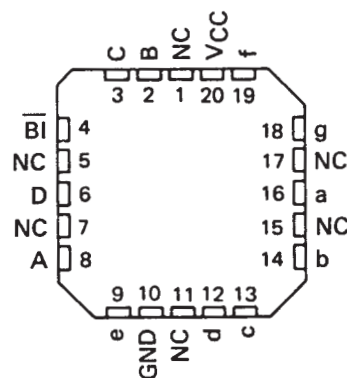

NC – No internal connection

PRODUCTION DATA information is current as of publication date. Products conform to specifications per the terms of Texas Instruments standard warranty. Production processing does not necessarily include testing of all parameters.

 **TEXAS
INSTRUMENTS**

POST OFFICE BOX 655303 • DALLAS, TEXAS 75265

Copyright © 1988, Texas Instruments Incorporated

SN5446A, '47A, '48, SN54LS47, 'LS48, 'LS49
 SN7446A, '47A, '48, SN74LS47, 'LS48, 'LS49
 BCD-TO-SEVEN-SEGMENT DECODERS/DRIVERS

SDLS111 – MARCH 1974 – REVISED MARCH 1988

- All Circuit Types Feature Lamp Intensity Modulation Capability

TYPE	DRIVER OUTPUTS				TYPICAL POWER DISSIPATION	PACKAGES
	ACTIVE LEVEL	OUTPUT CONFIGURATION	SINK CURRENT	MAX VOLTAGE		
SN5446A	low	open-collector	40 mA	30 V	320 mW	J, W
SN5447A	low	open-collector	40 mA	15 V	320 mW	J, W
SN5448	high	2-k Ω pull-up	6.4 mA	5.5 V	265 mW	J,W
SN54LS47	low	open-collector	12 mA	15 V	35 mW	J, W
SN54LS48	high	2-k Ω pull-up	2 mA	5.5 V	125 mW	J, W
SN54LS49	high	open-collector	4 mA	5.5 V	40 mW	J, W
SN7446A	low	open-collector	40 mA	30 V	320 mW	J, N
SN7447A	low	open-collector	40 mA	15 V	320 mW	J, N
SN7448	high	2-k Ω pull-up	6.4 mA	5.5 V	265 mW	J, N
SN74LS47	low	open-collector	24 mA	15 V	35 mW	J, N
SN74LS48	high	2-k Ω pull-up	6 mA	5.5 V	125 mW	J, N
SN74LS49	high	open-collector	8 mA	5.5 V	40 mW	J, N

logic symbols †

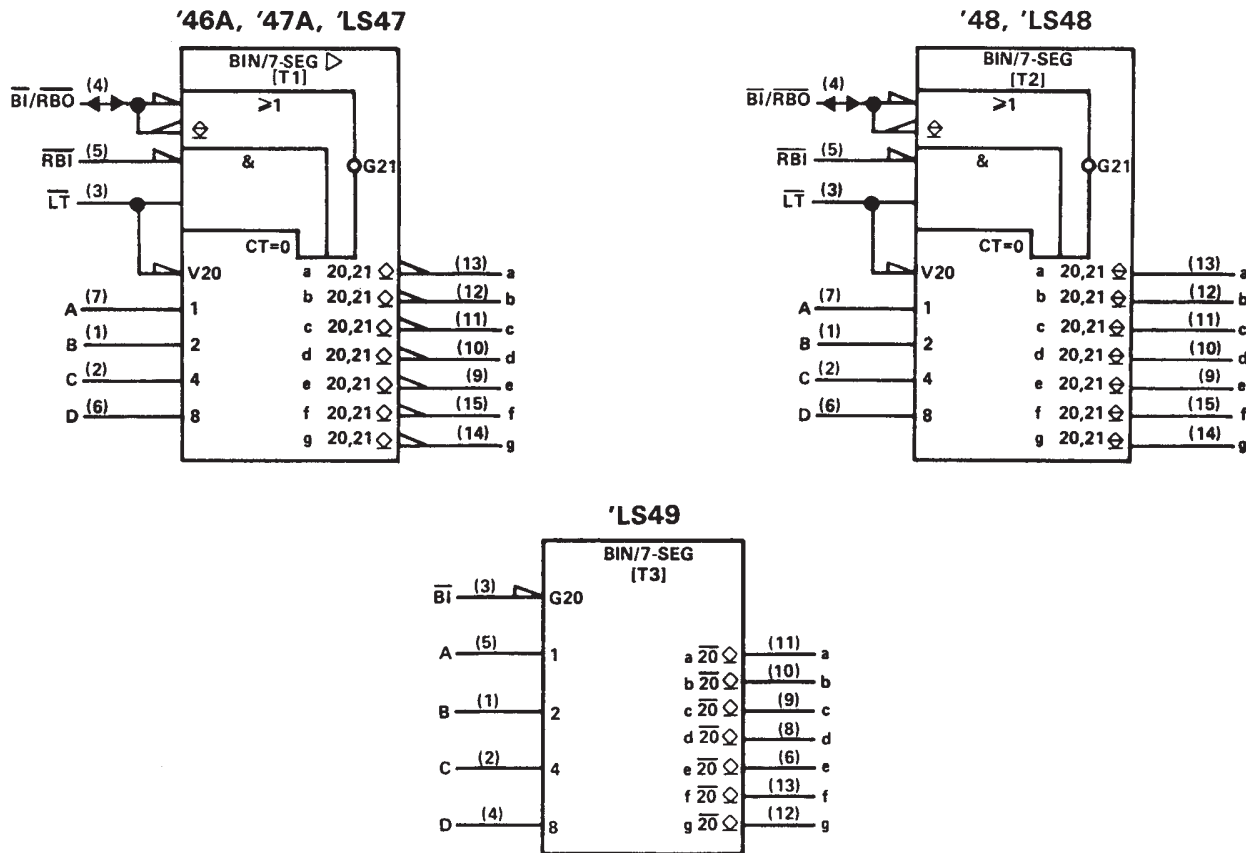

†These symbols are in accordance with ANSI/IEEE Std 91-1984 and IEC Publication 617-12. Pin numbers shown are for D, J, N, and W packages.



SN5446A, '47A, '48, SN54LS47, 'LS48, 'LS49 SN7446A, '47A, '48, SN74LS47, 'LS48, 'LS49 BCD-TO-SEVEN-SEGMENT DECODERS/DRIVERS

SDLS111 – MARCH 1974 – REVISED MARCH 1988

description

The '46A, '47A, and 'LS47 feature active-low outputs designed for driving common-anode LEDs or incandescent indicators directly. The '48, 'LS48, and 'LS49 feature active-high outputs for driving lamp buffers or common-cathode LEDs. All of the circuits except 'LS49 have full ripple-blanking input/output controls and a lamp test input. The 'LS49 circuit incorporates a direct blanking input. Segment identification and resultant displays are shown below. Display patterns for BCD input counts above 9 are unique symbols to authenticate input conditions.

The '46A, '47A, '48, 'LS47, and 'LS48 circuits incorporate automatic leading and/or trailing-edge zero-blanking control (\overline{RBI} and \overline{RBO}). Lamp test (\overline{LT}) of these types may be performed at any time when the $\overline{BI/RBO}$ node is at a high level. All types (including the '49 and 'LS49) contain an overriding blanking input (\overline{BI}), which can be used to control the lamp intensity by pulsing or to inhibit the outputs. Inputs and outputs are entirely compatible for use with TTL logic outputs.

The SN54246/SN74246 and '247 and the SN54LS247/SN74LS247 and 'LS248 compose the  and the  with tails and were designed to offer the designer a choice between two indicator fonts.

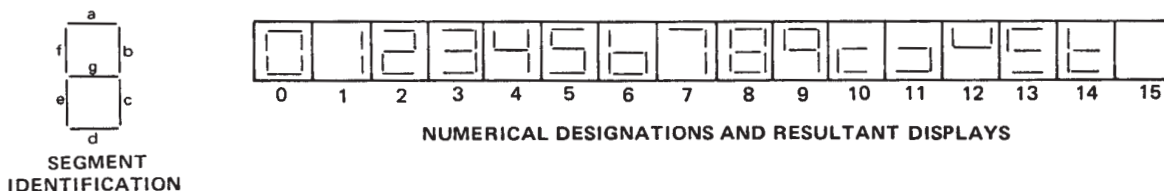

'46A, '47A, 'LS47 FUNCTION TABLE (T1)

DECIMAL OR FUNCTION	INPUTS						$\overline{BI/RBO}^\dagger$	OUTPUTS							NOTE	
	\overline{LT}	\overline{RBI}	D	C	B	A		a	b	c	d	e	f	g		
0	H	H	L	L	L	L	H	ON	ON	ON	ON	ON	ON	OFF	OFF	
1	H	X	L	L	L	H	H	OFF	ON	ON	OFF	OFF	OFF	OFF	OFF	
2	H	X	L	L	H	L	H	ON	ON	OFF	ON	ON	OFF	ON	ON	
3	H	X	L	L	H	H	H	ON	ON	ON	ON	OFF	OFF	ON	ON	
4	H	X	L	H	L	L	H	OFF	ON	ON	OFF	OFF	ON	ON	ON	
5	H	X	L	H	L	H	H	ON	OFF	ON	ON	OFF	ON	ON	ON	
6	H	X	L	H	H	L	H	OFF	OFF	ON	ON	ON	ON	ON	ON	
7	H	X	L	H	H	H	H	ON	ON	ON	OFF	OFF	OFF	OFF	OFF	
8	H	X	H	L	L	L	H	ON	ON	ON	ON	ON	ON	ON	ON	
9	H	X	H	L	L	H	H	ON	ON	ON	OFF	OFF	ON	ON	ON	
10	H	X	H	L	H	L	H	OFF	OFF	OFF	ON	ON	OFF	ON	ON	
11	H	X	H	L	H	H	H	OFF	OFF	ON	ON	OFF	OFF	ON	ON	
12	H	X	H	H	L	L	H	OFF	ON	OFF	OFF	OFF	ON	ON	ON	
13	H	X	H	H	L	H	H	ON	OFF	OFF	ON	OFF	ON	ON	ON	
14	H	X	H	H	H	L	H	OFF	OFF	OFF	ON	ON	ON	ON	ON	
15	H	X	H	H	H	H	H	OFF	OFF	OFF	OFF	OFF	OFF	OFF	OFF	
BI	X	X	X	X	X	X	L	OFF	OFF	OFF	OFF	OFF	OFF	OFF	OFF	2
RBI	H	L	L	L	L	L	L	OFF	OFF	OFF	OFF	OFF	OFF	OFF	OFF	3
LT	L	X	X	X	X	X	H	ON	ON	ON	ON	ON	ON	ON	ON	4

H = high level, L = low level, X = irrelevant

NOTES: 1. The blanking input (\overline{BI}) must be open or held at a high logic level when output functions 0 through 15 are desired. The ripple-blanking input (\overline{RBI}) must be open or high if blanking of a decimal zero is not desired.

2. When a low logic level is applied directly to the blanking input (\overline{BI}), all segment outputs are off regardless of the level of any other input.

3. When ripple-blanking input (\overline{RBI}) and inputs A, B, C, and D are at a low level with the lamp test input high, all segment outputs go off and the ripple-blanking output (\overline{RBO}) goes to a low level (response condition).

4. When the blanking input/ripple blanking output ($\overline{BI/RBO}$) is open or held high and a low is applied to the lamp-test input, all segment outputs are on.

$^\dagger \overline{BI/RBO}$ is wire AND logic serving as blanking input (\overline{BI}) and/or ripple-blanking output (\overline{RBO}).

SN5446A, '47A, '48, SN54LS47, 'LS48, 'LS49
 SN7446A, '47A, '48, SN74LS47, 'LS48, 'LS49
 BCD-TO-SEVEN-SEGMENT DECODERS/DRIVERS

SDLS111 – MARCH 1974 – REVISED MARCH 1988

'48, 'LS48
 FUNCTION TABLE (T2)

DECIMAL OR FUNCTION	INPUTS					$\overline{BI}/\overline{RBO}^\dagger$	OUTPUTS							NOTE
	\overline{LT}	\overline{RBI}	D	C	B		A	a	b	c	d	e	f	
0	H	H	L	L	L	L	H	H	H	H	H	H	L	1
1	H	X	L	L	L	H	H	L	H	H	L	L	L	
2	H	X	L	L	H	L	H	H	H	L	H	H	L	
3	H	X	L	L	H	H	H	H	H	H	L	L	H	
4	H	X	L	H	L	L	H	L	H	H	L	L	H	
5	H	X	L	H	L	H	H	H	L	H	H	L	H	
6	H	X	L	H	H	L	H	L	L	H	H	H	H	
7	H	X	L	H	H	H	H	H	H	H	L	L	L	
8	H	X	H	L	L	L	H	H	H	H	H	H	H	
9	H	X	H	L	L	H	H	H	H	L	L	H	H	
10	H	X	H	L	H	L	H	L	L	L	H	H	L	
11	H	X	H	L	H	H	H	L	L	H	H	L	L	
12	H	X	H	H	L	L	H	L	H	L	L	L	H	
13	H	X	H	H	L	H	H	H	L	L	H	L	H	
14	H	X	H	H	H	L	H	L	L	L	H	H	H	
15	H	X	H	H	H	H	H	L	L	L	L	L	L	
BI	X	X	X	X	X	X	L	L	L	L	L	L	L	2
RBI	H	L	L	L	L	L	L	L	L	L	L	L	L	3
LT	L	X	X	X	X	X	H	H	H	H	H	H	H	4

H = high level, L = low level, X = irrelevant

- NOTES: 1. The blanking input (\overline{BI}) must be open or held at a high logic level when output functions 0 through 15 are desired. The ripple-blanking input (\overline{RBI}) must be open or high, if blanking of a decimal zero is not desired.
2. When a low logic level is applied directly to the blanking input (\overline{BI}), all segment outputs are low regardless of the level of any other input.
3. When ripple-blanking input (\overline{RBI}) and inputs A, B, C, and D are at a low level with the lamp-test input high, all segment outputs go low and the ripple-blanking output (\overline{RBO}) goes to a low level (response condition).
4. When the blanking input/ripple-blanking output ($\overline{BI}/\overline{RBO}$) is open or held high and a low is applied to the lamp-test input, all segment outputs are high.

$^\dagger \overline{BI}/\overline{RBO}$ is wire-AND logic serving as blanking input (\overline{BI}) and/or ripple-blanking output (\overline{RBO}).

'LS49
 FUNCTION TABLE (T3)

DECIMAL OR FUNCTION	INPUTS					\overline{BI}	OUTPUTS							NOTE
	D	C	B	A	a		b	c	d	e	f	g		
0	L	L	L	L	L	H	H	H	H	H	H	L	1	
1	L	L	L	H	L	H	L	H	H	L	L	L		
2	L	L	H	L	L	H	H	H	L	H	H	L		
3	L	L	H	H	L	H	H	H	H	H	L	L		
4	L	H	L	L	L	H	L	H	H	L	L	H		
5	L	H	L	H	L	H	H	L	H	H	L	H		
6	L	H	H	L	L	H	L	L	H	H	H	H		
7	L	H	H	H	L	H	H	H	H	L	L	L		
8	H	L	L	L	L	H	H	H	H	H	H	H		
9	H	L	L	H	L	H	H	H	H	L	L	H		
10	H	L	H	L	L	H	L	L	L	H	H	L		
11	H	L	H	H	L	H	L	L	H	H	L	L		
12	H	H	L	L	L	H	L	H	L	L	L	H		
13	H	H	L	H	L	H	H	L	L	L	H	L		
14	H	H	H	L	L	H	L	L	L	L	H	H		
15	H	H	H	H	L	H	L	L	L	L	L	L		
BI	X	X	X	X	X	L	L	L	L	L	L	L	2	

H = high level, L = low level, X = irrelevant

- NOTES: 1. The blanking input (\overline{BI}) must be open or held at a high logic level when output functions 0 through 15 are desired.
2. When a low logic level is applied directly to the blanking input (\overline{BI}), all segment outputs are low regardless of the level of any other input.

