



2014 ASEE MODEL DESIGN COMPETITION

Sponsored by the Two Year College Division of ASEE

Date: June 24, 2013

Dear Colleague,

On behalf of the American Society for Engineering Education (ASEE) - Two Year College Division (TYCD), we invite you to encourage the submission of student design projects for the 16th Annual ASEE Lower Division MODEL DESIGN COMPETITION. This event will be held in conjunction with the 2014 ASEE Annual Convention, Indianapolis, Indiana, June 15 - 18, 2014. This competition is open to 1st and 2nd year students at four and two year colleges and universities.

In this year's competition student teams will design and build a robot that can complete as many laps around an oval track in each of four trials. The robot must adhere to the rules of the model design competition (attached). An exhibit session is included as part of the competition.

The main reason for this competition is for students to gain a better understanding of the design process from start to finish. Designing and building something from an idea is probably why they chose engineering in the first place. Use this design competition as a platform to reinforce their ideas and have some *engineering fun!* We hope to see you and your students' entries in Indianapolis.

Please find enclosed the guidelines and registration forms for this event. The interest and registration forms are on the back of this letter.

Sincerely,

Paul E. Gordy
Phone: 757-822-7175
Fax: 757-427-0327
Email: pgordy@tcc.edu

John Wadach
Phone: 585-292-2488
Email: jwadach@monroecc.edu

Results from the
15th Annual ASEE Model Design Competition
June 24, 2013 - Atlanta, Georgia

The recent competition in Atlanta required teams to design and build an autonomous robot that could collect 12 orange colored golf balls that represented ripe Georgia peaches and deposit them in the peach basket in the center of the track. The robot had to begin within an 8" X 12" X 10" high size but was allowed to expand to any size after the trial had begun. Teams had a maximum time of 60 seconds to collect all the peaches and deposit them in the peach basket.

___ teams competed and the results were as follows:

1st Place – _____
2nd Place – _____
3rd Place – _____

[INSERT PICTURE OF ALL TEAMS FROM ATLANTA HERE]

For complete results, including scores, pictures, videos, and more, visit the competition websites at <http://www.tcc.edu/faculty/webpages/pgordy/ASEE/index.html> and at <https://www.facebook.com/MCCELC> .

Consider bringing a team from your college to next year's competition on June 16, 2014 in Indianapolis, Indiana. For more information or a copy of next year's rules, please contact Paul Gordy, pgordy@tcc.edu, 757-822-7175) or John Wadach, Jwadach@monroecc.edu, 585-292-2488).

2014 ASEE TYCD MODEL DESIGN COMPETITION RULES
Indianapolis, Indiana
June 16, 2014

The 16th Annual American Society for Engineering Education (ASEE) Two-Year College Division (TYCD), Model Design Competition will be held Monday, June 16, 2014 in conjunction with the ASEE Annual Convention in Indianapolis, Indiana.

Event Name: Mini Indy

Objective:

To design and build an autonomous robot that can complete as many laps around an oval track in each of four 60 second trials. In trials 1 and 2, the track will not contain any other “cars” on the track. In trials 3 and 4, two wooden blocks will be placed on the track to represent cars that robots must navigate around. The robot must remain within an 8” X 12” X 10” high size limit at all times during a trial.

Track Specifications:

Figure 1: Isometric View of the Track used for Trials 1 and 2

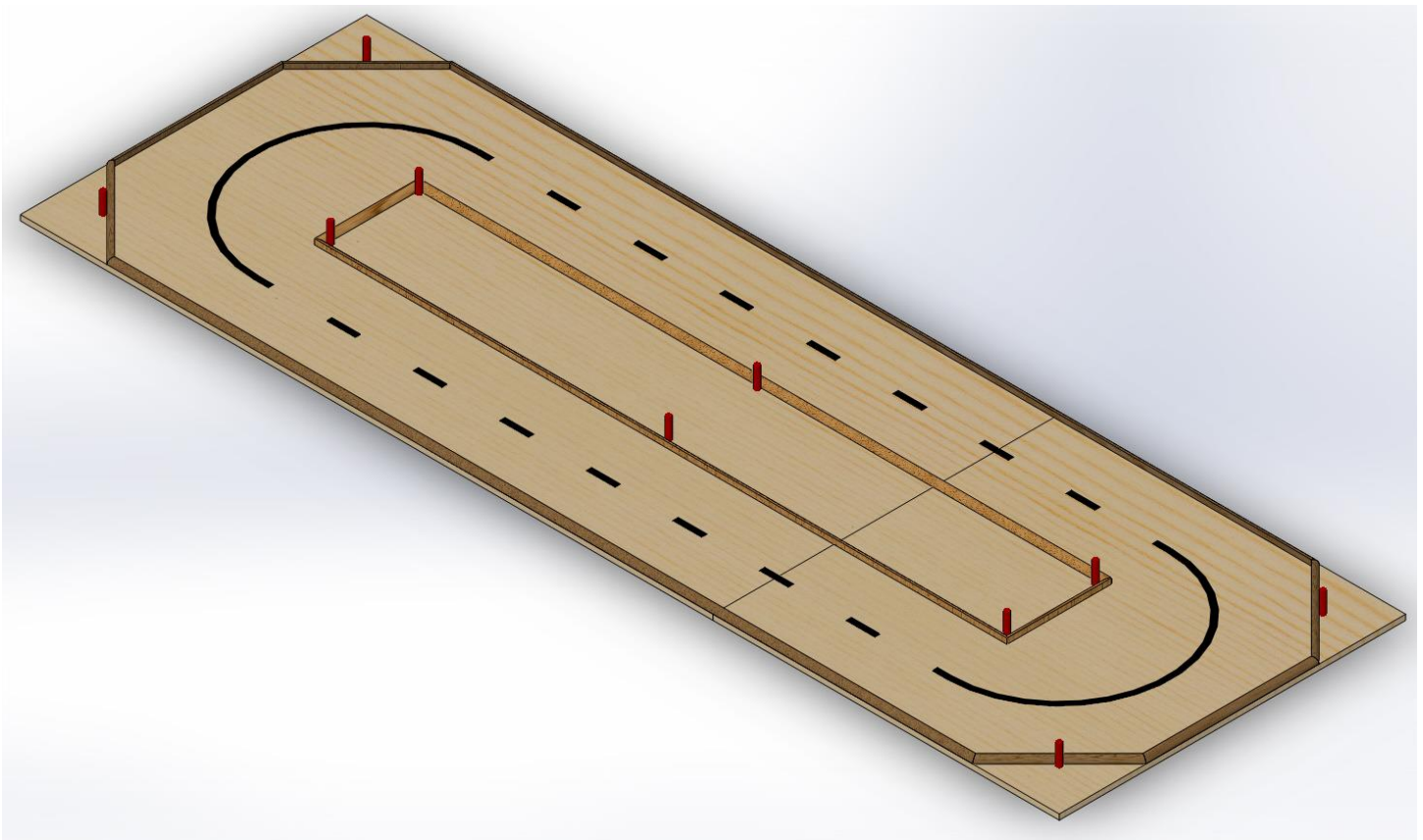

Figure 2: Top View of the Track for Trials 1 and 2
 (Sheet scale may not be accurate due to document magnification)

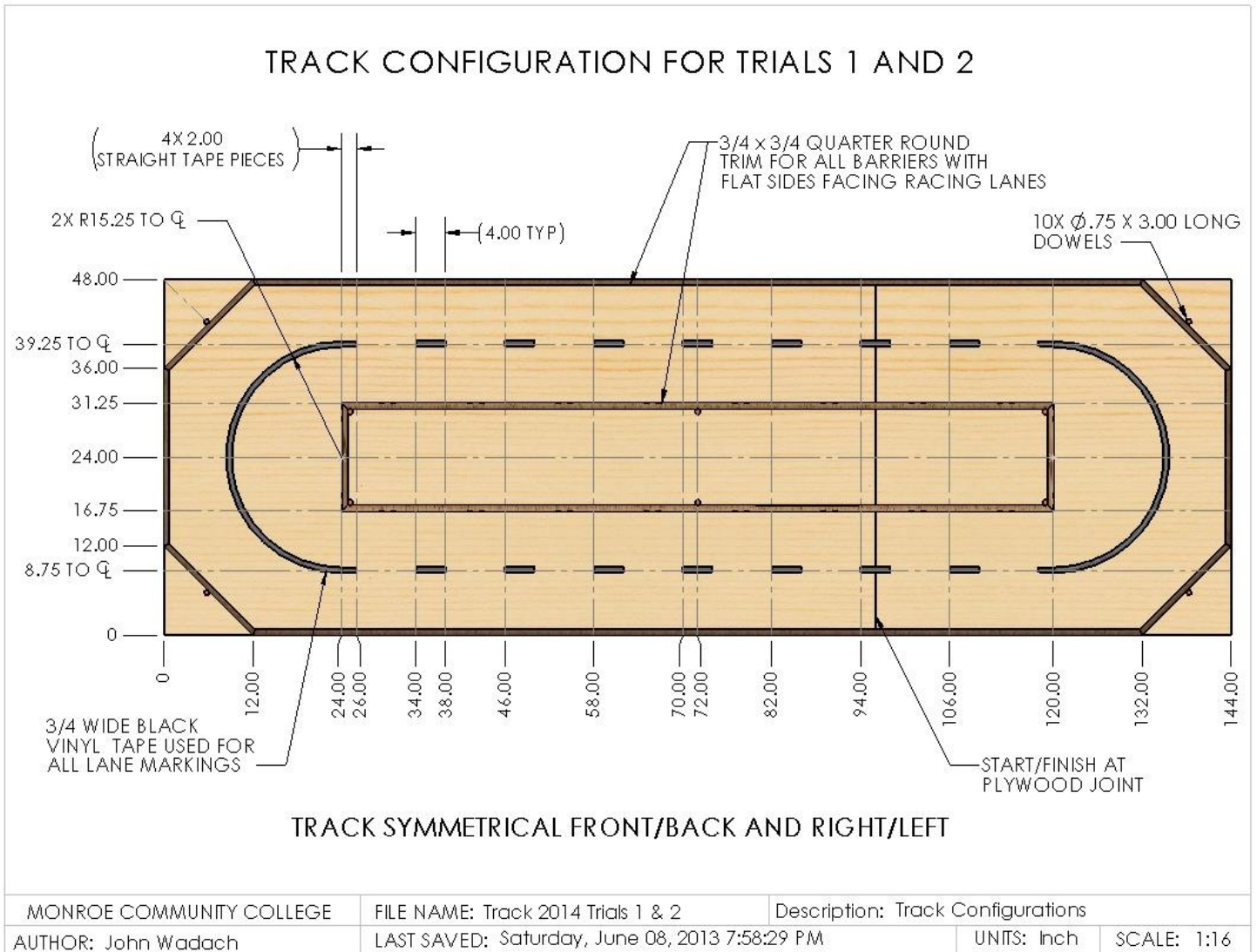

Figure 3: Section View with the Track Cut at the Joint Between the Sheets of Plywood
 (Notice that the Flat Sides of the Quarter Round Trim Face the Racing Lanes)

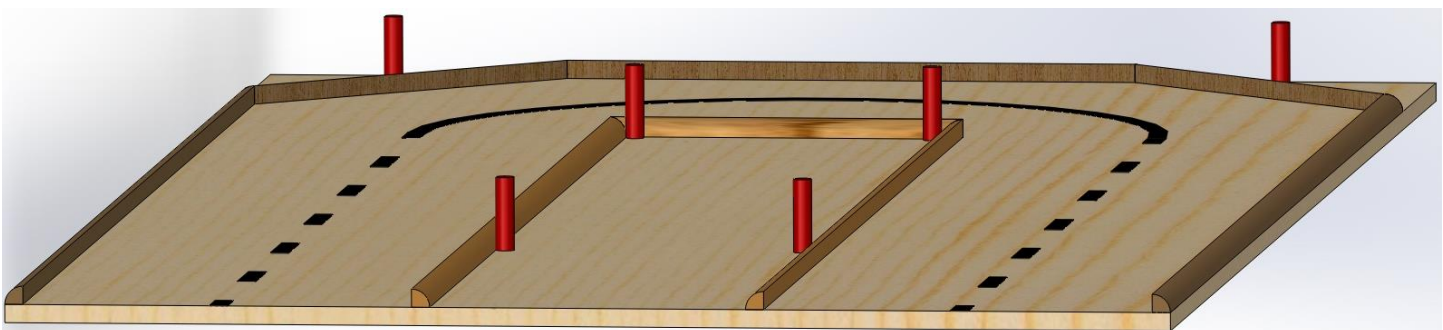

Figure 4: Isometric View of the Track in the “HEADS” Configuration for Trials 3 and 4

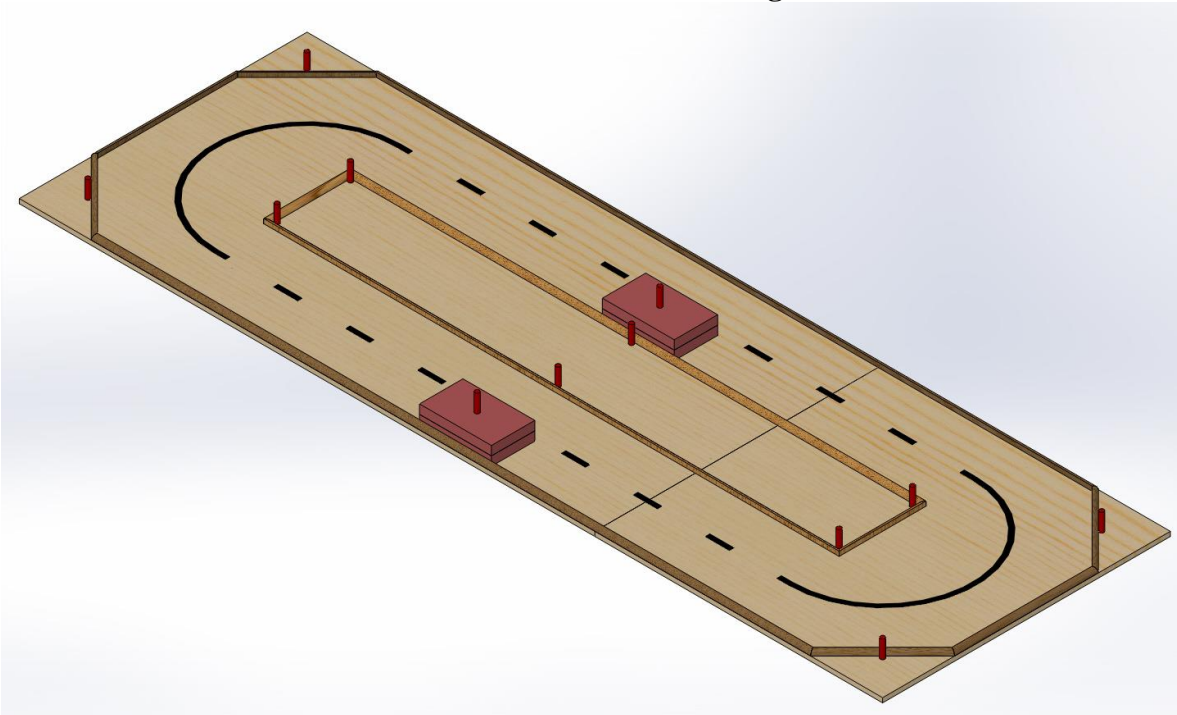

Figure 5: Top View of the Track in the “HEADS” Configuration for Trials 3 and 4 (Sheet scale may not be accurate due to document magnification)

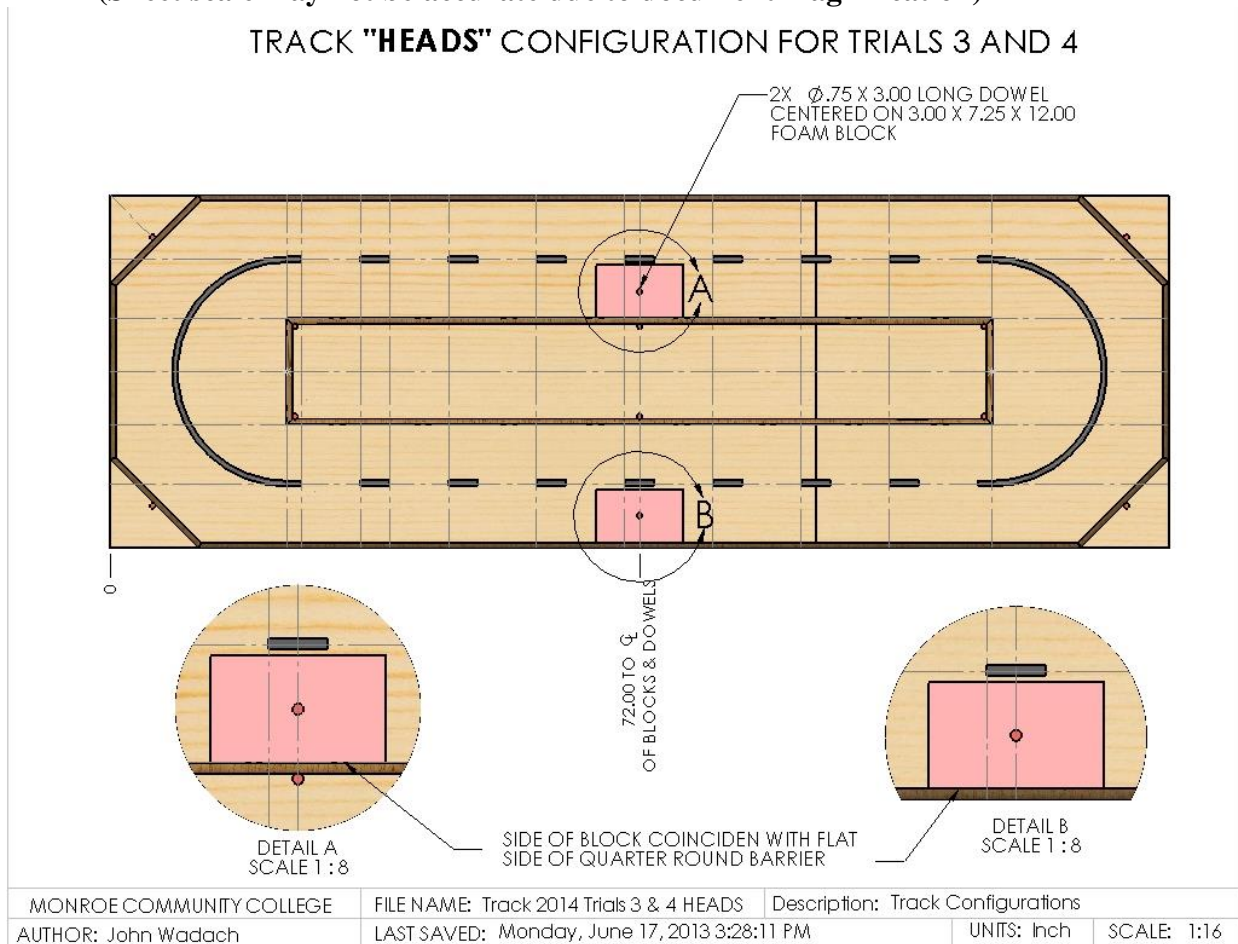

Figure 6: Isometric View of the Track in the "TAILS" Configuration for Trials 3 and 4

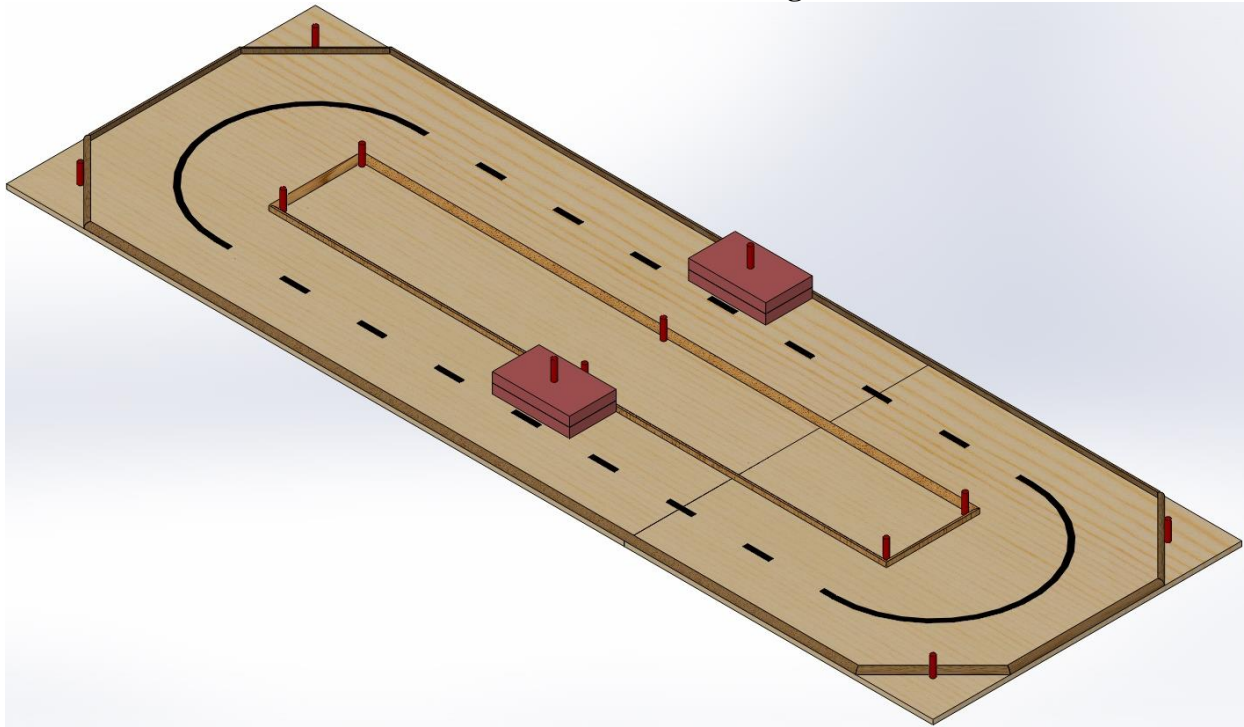

Figure 7: Top View of the Track in the "TAILS" Configuration for Trials 3 and 4 (Sheet scale may not be accurate due to document magnification)

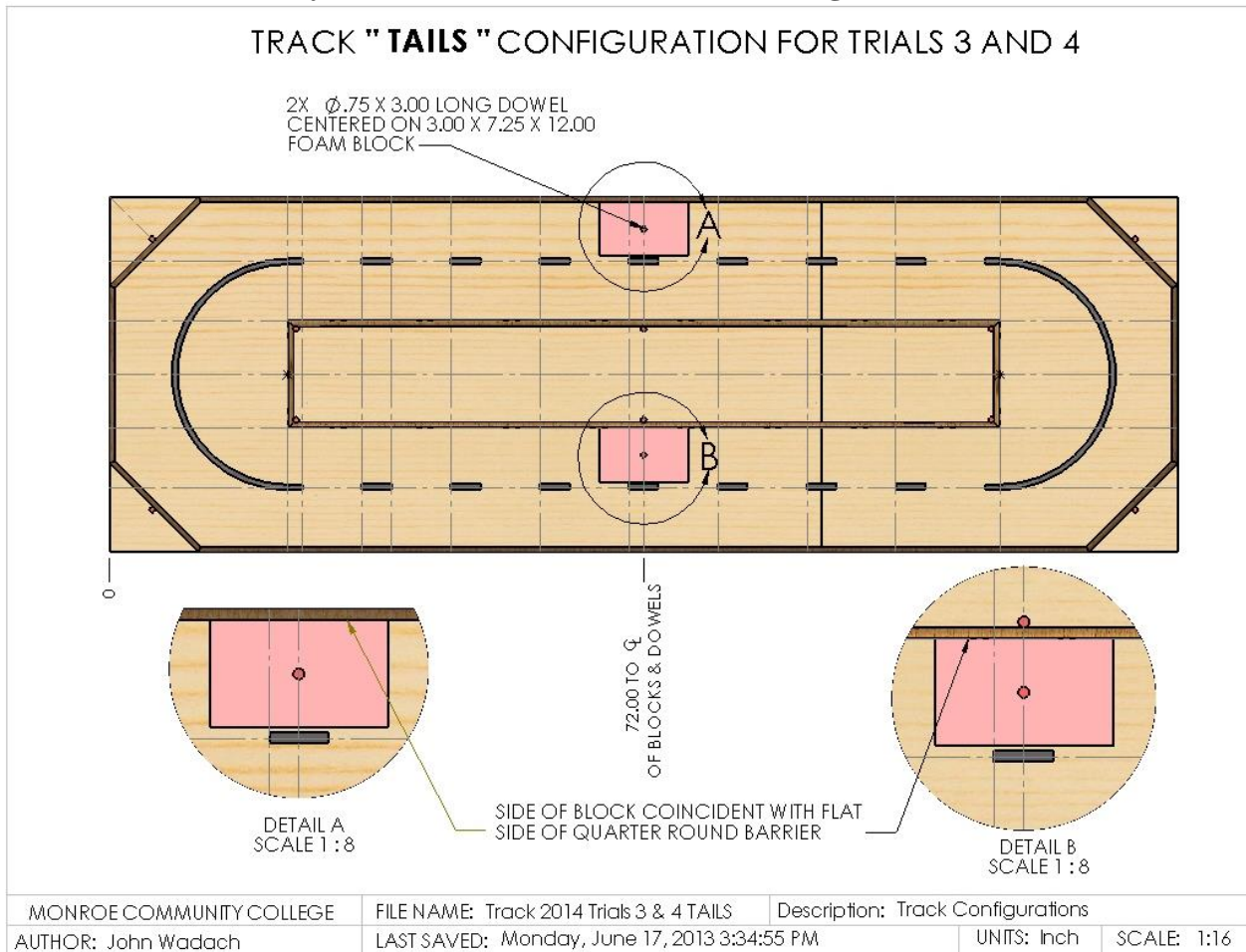
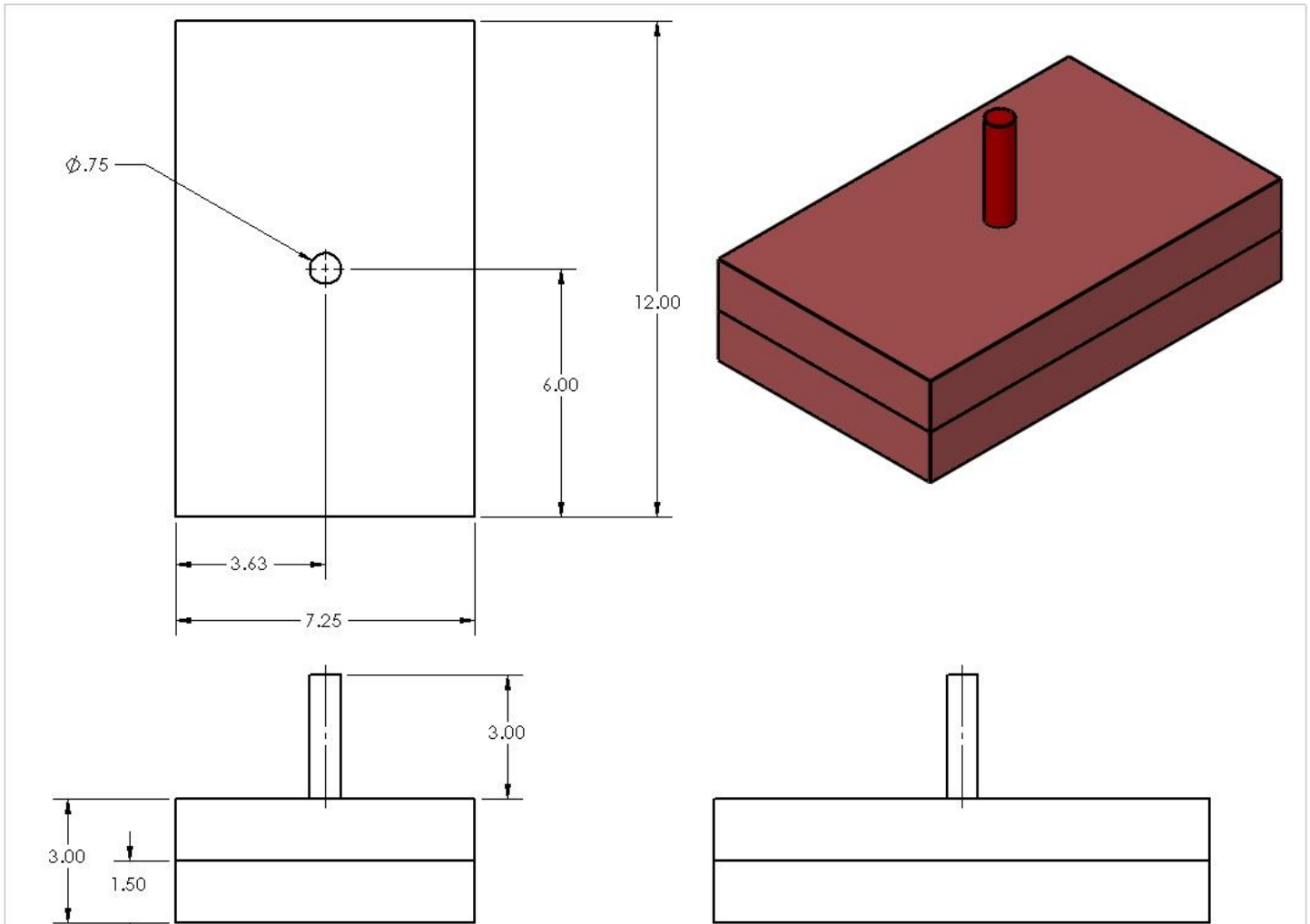
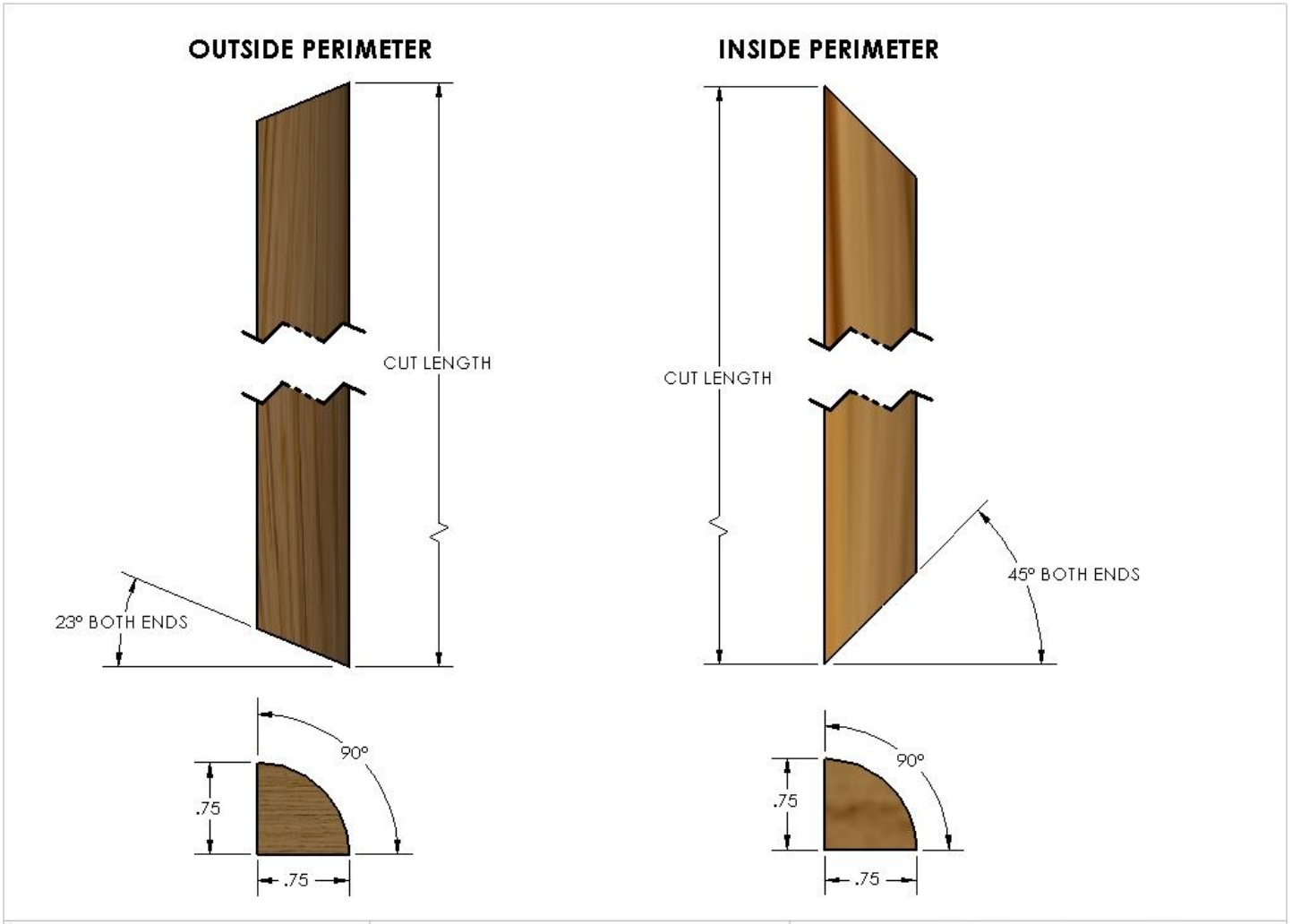

Figure 8: Views of the Foam Blocks and Dowel used for Trials 3 and 4
 (Sheet scale may not be accurate due to document magnification)



MONROE COMMUNITY COLLEGE AUTHOR: John Wadach	FILE NAME: 3 x 7.25 x 12 Car and Dowel Drawing LAST SAVED: Monday, June 17, 2013 2:51:33 PM	Description: Two 1.5" Thick Foam Boards and Dowel UNITS: Inch SCALE: 1:3
---	--	---

Figure 9: Views of the Perimeter Trim Boards
 (Sheet scale may not be accurate due to document magnification)



MONROE COMMUNITY COLLEGE	FILE NAME: Quarter Round Trim	Description: 3/4 x 3/4 Quarter Round Trim	
AUTHOR: John Wadach	LAST SAVED: Monday, June 10, 2013 9:01:50 PM	UNITS: Inch	SCALE: 1:1

Required Materials:

1. **One** 4' X 8' X 3/4" sheet BC grade or better grade plywood.
2. **One** 4' X 4' X 3/4" sheet BC grade or better grade plywood.
3. **Two** 3/4" x 3/4" x 120.0" Quarter Round Outside Perimeter Boards (see fig. 9)
4. **Two** 3/4" x 3/4" x 24.0" Quarter Round Outside Perimeter Boards (see fig. 9)
5. **Two** 3/4" x 3/4" x 17.0" Quarter Round Outside Perimeter Boards (see fig. 9)
6. **Two** 3/4" x 3/4" x 96.0" Quarter Round Inside Perimeter Boards (see fig. 9)
7. **Two** 3/4" x 3/4" x 14.5" Quarter Round Inside Perimeter Boards (see fig. 9)
8. **One** Roll of 3/4" Wide Black Vinyl Tape
9. **Two** (2" x 4" Nominal Size) x 144" boards for substructure framing
10. **Thirteen** (2" x 4" Nominal Size) x 45" boards for substructure framing
11. **Four** 1.5" x 8" x 12" pieces of rigid extruded polystyrene foam insulation board cut from Owens Corning Foamular InsulPink R-7.5 1-1/2 in. x 2 ft. x 8 ft. Furring Lap Foam or similar material. Alternately **Six** 1.0" x 8" x 12" pieces could be substituted and cut from Owens Corning Foamular F-250 1 in. x 24 in. x 96 in. Tongue and Groove Foam. Both products are listed on the HomeDepot.com website.
12. **Twelve** 0.75" Diameter X 3.0" Long dowels either natural wood or painted any desired color
13. **One** Box of 2.5" or 3.0" Wood Screws for substructure framing
14. **One** Box of 1.5" Finishing Nails for attaching the plywood to the substructure and perimeter boards to the plywood.
15. **One** container of light pine colored Sandable Wood Filler.
16. **One** package of 150 grit sandpaper
17. **One** package of tack cloths

Construction Procedures:

1. Layout the two (2" x 4" Nominal Size) x 144" boards parallel to each other and mark the locations for the 45" stud locations so that they are 16" on-center. Attach studs to the 144" boards using two wood screws on each side.
2. After the substructure is square, fasten the 3/4" thick plywood using 1.5" finishing nails. Set the nails and fill the holes with putty. Once the putty has dried, sand it flat.
3. Draw light construction lines on the plywood as shown in figure 2 to locate the positions of the perimeter boards and the pieces of black vinyl tape.

4. Apply the 3/4" wide black vinyl tape to the plywood. Be sure not to stretch the tape during application or else the tape will lose adherence to the track over time.
5. Miter the ends of all quarter round boards to the proper lengths (see figure 9). Pre-drill holes in the boards every 8 to 12" for nail locations so that the boards do not split.
6. Fasten the perimeter boards to the track using 1.5" finishing nails so that the flat side of the trim faces the racing lanes (see figure 3). Set the nails, fill with putty. When the putty is dry, sand it flat.
7. Sand off any stray marks on the plywood and then dust the plywood with tack cloths.
8. To create the mock cars for trials 3 and 4, cut pieces rigid extruded polystyrene and glue them together to form a 3.0" high X 7.25" Wide X 12.0" long block (see figure 8). The sides of the blocks must be smooth and flat. If you are cutting pieces of foam from tongue and groove sheets, be sure to cut away the tongue and groove edges.
10. Dowels that are placed on the track rest on the surface of the plywood. No positioning holes will be drilled. Likewise, the dowels that will be placed on the foam blocks will rest on the surface of the foam and not inserted into a hole. The purpose of the dowels is to constrain the motion of the robots by ending a trial if any dowel is knocked over.

Vehicle Specifications:

Allowable Energy Sources:

Any energy source is allowed as long as it is completely contained within the robot and does not create or emit any gaseous, liquid, or solid emissions. Energy sources must not present any safety hazards to participants or spectators.

Maximum Robot Size:

The robot must fit inside a box with vertical sides having inside dimensions of 8.0" X 12.0" and have a maximum height of 10.0". The robot must remain within this size constraint for the entire duration of a trial. If minor parts fall off the robot such as fasteners or hardware during a trial, the robot will still be considered within the size constraint as long as the remaining robot stays within the 8.0" X 12.0" X 10.0" high limit.

Components, Fabrication, and Cost:

Team members using materials which are commonly available to the general public must perform all fabrication. Use of commercially available vehicles, robots, or entire kits such as RC cars, Legos, K-nex, Fischer-Technics, Parallax or erector sets may not be used. The use of **Lego Mindstorm microcontroller bricks are prohibited**. Individual components from these cars, robots, or kits (except the Mindstorm Brick) may be integrated into a team's robot as long as the majority of the robot's components are not from the same car, robot, or kit source. The cost of purchasing all components must not exceed **\$400**.

Robot Time Trial Rules:

- 1) It is the responsibility of the team to inspect the condition of the track before starting their robot to be certain that everything is in order. Once a team presses or pulls the start mechanism, the run counts as an official trial and may not be done over.
- 2) The order of testing will be determined by random draw.
- 3) While the preceding team is on the track for a trial, the on-deck team must have their robot on the on-deck table ready to run immediately after the previous team completes their trial. Each team will have one minute to begin a trial after being called.
- 4) All teams will be called for a trial in a current round before any teams begin the next round of testing.
- 5) Robot sizes will be tested with the measuring box prior to each team's first run and in subsequent runs if requested by the judges. Team members will be responsible for placing the measuring box over their robots. If a robot fails to meet the size constraint the judges will assess a penalty proportional to the severity of the violation.
- 6) The Start/Finish line is located at the joint between the 4' x 8' and 4' x 4' sheets of plywood. All robots must traverse the track in a counterclockwise direction as viewed from above the track. The side of the joint nearest to the first turn is the Start/Finish line. See figure 10 below.

Figure 10: Start/Finish Line Location and Initial Direction of travel.



**START/FINISH LINE LOCATED
AT PLYWOOD JOINT**

**DIRECTION OF TRAVEL
AT START OF RACE**

- 7) The robot must start so that all contact points between the robot and the track are between the planes defined by the flat vertical sides of the inside and outside perimeter boards. In addition, all parts of the robot must be behind a vertical plane coincident with the Start/Finish line.
- 8) The time for a trial will begin when the judge gives the team the command to start. Once this start command is given, a team may only activate a single switch or mechanism to start the robot. This switch or

mechanism may not have multiple ways in which it can be activated for the purpose of communicating the configuration of the track to the robot. Once the robot begins to move in any way, team members may not touch the robot or communicate with it with any remote control device.

- 9) If a robot fails to move once the judge's start command is given, the team members may work on their robot to get it moving but the time will continue to run from the time when the start command was given. If the robot has not moved within 60 seconds of the start command, a score of zero will be assigned for that trial.
- 10) A trial will end when any of the following actions occur:
 - a. Any part of the robot makes contact with a plywood surface outside of the inside and outside perimeter boards. These forbidden surfaces are the areas where the dowels are located.
 - b. The robot knocks over any dowel.
 - c. The robot no longer makes progress toward completing additional laps.
 - d. 60 seconds elapses since the start command for trials 1 and 2. This time limit is increased to 75 seconds for trials 3 and 4.
 - e. 5 laps are completed (this is a perfect run).
- 11) In trials 1 and 2 the track will not contain any obstacles in the driving lanes as shown in figures 1, 2 and 10.
- 12) In trials 3 and 4 the following additional procedures will be employed.
 - a. The team must place their robot on the track as specified in rule 7 above.
 - b. The judge will flip a coin to determine whether the two foam blocks and dowels will be configured in the "Heads" (figures 4 and 5) or "Tails" (figures 6 and 7) configuration.
 - c. The team may not communicate to their robot in any way to indicate which configuration the track is in. The intent of trials 3 and 4 is to have the robot avoid the two obstacles without knowing which configuration the track has been set up in.
 - d. A robot may not touch the dowel on the top of the foam block to prevent it from falling over.
 - e. The blocks may not be moved by a robot more than 1" even if the dowel does not fall over.
 - f. The trial will begin as specified in rule 8.
- 13) Teams may make changes or repairs to their robots between trials but they must be ready within one minute of being called to the track.
- 14) **Teams may not make practice runs during the Exhibit Session or after the start of the Robot Time Trials.**

Robot Time Trial Scoring:

Robots will earn points as described below.

Trials 1 and 2:

1. **10 Points** will be awarded for each lap completed prior to the end of a trial. No points will be awarded for completion of a partial lap.
2. If a robot completes 5 laps in less than 60 seconds a time bonus of (60 – time in seconds to complete 5 laps) will be added to the trial score.

Trials 3 and 4:

2. **20 Points** will be awarded for each lap completed prior to the end of a trial. No points will be awarded for completion of a partial lap.
2. If a robot completes 5 laps in less than 75 seconds a time bonus of $(75 - \text{time in seconds to complete 5 laps})$ will be added to the trial score.

Exhibit Session Scoring:

A maximum score of 120 points may be earned in the Exhibit Session. Scoring details are described on the next page.

Overall Scoring:

The overall score for a team will be equal to the sum of the scores for the Exhibition Session and the four Robot Time Trials. A team will be disqualified from the competition if they fail to participate in the entire Exhibition Session.

Overall Score = Sum of the Points from all four Robot Time Trials + Exhibition Session Point Total

Exhibit Session:

Prior to the Robot Time Trials, each team must participate in an exhibit session where they will create a booth to promote their project to judges, other students, and conference attendees. Each team will be supplied with a 6' long table, a tripod display frame, and electrical power. The entire session is scheduled to last approximately 3 hours during the grand opening of the Exhibition Hall on Monday, June 16th.

All participants must be present during the entire exhibit session. Teams may use posters, written documents, physical prototypes, multimedia displays, and other visual aids at their booths. In addition, each team's robot must remain on display at their booth for the entire duration of the exhibit session. **Team members may neither work on, nor test their robots during this session.** The number of entries from a given school will be limited by the available space during the exhibit session.

Students from each team are required to visit the exhibits from all other schools. A captain from each school will score each team from other schools on a scale from 0-20 (20 being best) based upon the criteria that the judges will use. Each school will designate a single captain even if that school has multiple teams. The captains' score will be computed by deleting the highest and lowest scores from the captains and then computing the average of the remaining scores.

The judges will visit each booth for approximately 10 minutes depending on the number of teams competing. During this visit, team members will guide the judges through their display for the first five minutes. In the second 5 minute period, the judges will ask the team questions. Each judge will score teams on a scale of 0 to 20 (20 being best) on the first five items below. The score in each category will be computed by deleting the highest and lowest scores from the judges, and then computing the average of the remaining scores.

1. Design Evolution:

Guide the judges through the design process that your team followed from the initial ideas to the final solution. Describe your rationale for making design decisions.

2. Robot Operation:

Discuss how your robot works.

3. Fabrication Methods:

Explain how you fabricated your robot.

4. Design Analysis:

Convince the judges that your design is optimal based upon its performance, cost, and environmental impact.

5. Exhibit Quality:

Your exhibit quality will be judged on the following items: team and exhibit appearance, technical expertise displayed, communication skills, and effectiveness of visual aids.

6. Captain Scoring:

The score from the captains will be added to the judges' scores from the five categories above.

Rule Interpretation Questions:

Prior to the date of the competition direct your inquiries to:

John Wadach
Monroe Community College
1000 E. Henrietta Road
Rochester, NY 14623
Phone: 585-292-2488
Email: jwadach@monroecc.edu

On the date of the competition:

The judges will interpret the intent of the rules and make all decisions. If the judges determine that a team is in violation of the intent of any rule or specification, they will deduct points in proportion to the severity of the violation. All decisions by the judges are final and may not be appealed. Teams have shown respect for the judges, participants, and spectators in the past, and this positive attitude is expected from each participant this year.

Competition Registration Questions:

Questions related to registering for the competition should be directed to:

Paul Gordy
Tidewater Community College
1700 College Crescent
Virginia Beach, VA 23453
Phone: 757-822-7175
Email: pgordy@tcc.edu

Please find the entry forms on pages 11 and 12. The Interest Form should be received no later than April 1, 2014. A Registration Form for each model design team must be received no later than June 1, 2014.

PROJECT TEAM / ENTRY LIMITATIONS:

Each team must have at least one faculty advisor and at least 2 student members but no more than 10 student members. Each team member must primarily be enrolled in freshmen or sophomore level classes. The number of entries from each school will be limited by the space available in the Exhibit Session. If a school has more than one entry then each team must represent a unique solution to the design problem. Multiple copies of the same solution are prohibited.

ASEE ANNUAL CONVENTION PASSES:

It is not required that student team members or faculty advisors be registered for the ASEE Annual Convention. Passes will be provided for all team members and advisors so that they can enter the conference area and exhibition area on the day of the competition. Details for obtaining passes will be made available a couple of weeks prior to the competition.

COMPETITION TIMELINE:

The specific time and location of the Exhibit Session and Robot Testing will be sent to all teams and published in the ASEE Final Program and Proceedings booklet. The overall format of the competition is given below.

Morning: Exhibit Session

Afternoon: Robot Testing Session and Awards

PRACTICE SESSION:

It is expected that two tracks will be ready for teams to practice on by Sunday morning, June 15th. Teams should be considerate and only use the tracks for brief periods if other teams are waiting to use the tracks.

On the day of the competition the tracks will be available in the Exhibition Hall for teams to practice on prior to and following the Exhibit Session. No practice runs may be made during the Exhibit Session or after the Robot Time Trials have begun.

AWARDS:

First, second, and third-place teams will receive plaques.

SUNY TYESA COMPETITION

The State University of New York Two Year Engineering Science Association (SUNY TYESA) will host a design-build competition on at the end of April 2014. SUNY TYESA will use the same rules and project as the 2014 ASEE Design Competition. Teams interested in participating in the SUNY TYESA competition should contact Mark Courtney mcourtne@sunydutchess.edu or visit the SUNY TYESA website at: tyesa.org

2014 ASEE Model Design Competition Registration Form

Name of college/university: _____

Team Name: _____

Name of faculty advisor(s): _____

Mailing Address: _____

Phone: _____ Fax: _____

Email (print clearly): _____

Student team captain: _____

Other student team members:

1. _____ 2. _____ 3. _____

4. _____ 5. _____ 6. _____

7. _____ 8. _____ 9. _____

Which students/advisors need badges for the convention center? (Badges are needed if you are not registered for the convention).
Circle one: **All need badges** **None need badges** **Only those listed below need badges**

Will your team require electrical power at your Exhibition Table? Circle one: **YES** **NO**

Please submit this form to : Paul E. Gordy
 Tidewater Community College
 1700 College Crescent
 Virginia Beach, VA 23453
 Phone: 757-822-7175
 Fax: 757-822-7334
 Email: PGordy@tcc.edu

**Return one copy of this form for each team entered by
June 1, 2014 (by US mail , fax, or email)**

2014 ASEE Model Design Competition Interest Form

Name of college/university: _____

Name of faculty advisor(s): _____

Mailing Address: _____

Phone: _____ Fax: _____

Email (print clearly): _____

Number of model entries desired : _____

Please submit this form to: Paul E. Gordy
Tidewater Community College
1700 College Crescent
Virginia Beach, VA 23453
Phone: 757-822-7175
Fax: 757-822-7334
Email: PGordy@tcc.edu

Return this form by April 1, 2014 (by US mail , fax, or email)